

# Meet

## DINO 135T

### DINO® TRAILER MOUNTED MEWPs

#### Standard features in DINO 135T:

- Lightweight, robust, cost-effective
- Driving system; easy to move at work site
- Spacious, easy-entry basket; capacity 215 kg
- Large outrigger pads 280 x 360 mm
- Continuous rotation of the boom; easy and functional
- Basket rotation 90°
- Proportional controls
- Stable to tow, easy to transport
- Simple to use, clear and informative controls



#### Options available for DINO 135T:

- Petrol power pack
- Cable steering for driving
- Outrigger support indicator
- LED working lights
- DINO SafeGuard secondary guarding
- Extra outrigger pads 500 x 500 x 35 mm+ bracket
- Lockable tool / harness box
- Rack for tools and accessories
- Spare wheel

Technical data	135T
Max. working height	13.50 m
Max. platform height	11.50 m
Max. outreach	9.10 m
Support width	3.8 / 4.2 m
Lifting capacity	215 kg
Basket size	0.7 x 1.3 m
Boom rotation	cont.
Basket rotation	90°
Boom control	proport.
Transport length	5.96 m
Transport width	1.78 m
Transport height	2.16 m
Weight	1635 kg
Driving system	std
AC socket in the basket x 2	std
Electro motor	std
Petrol power pack	opt.
Gradeability	25 %

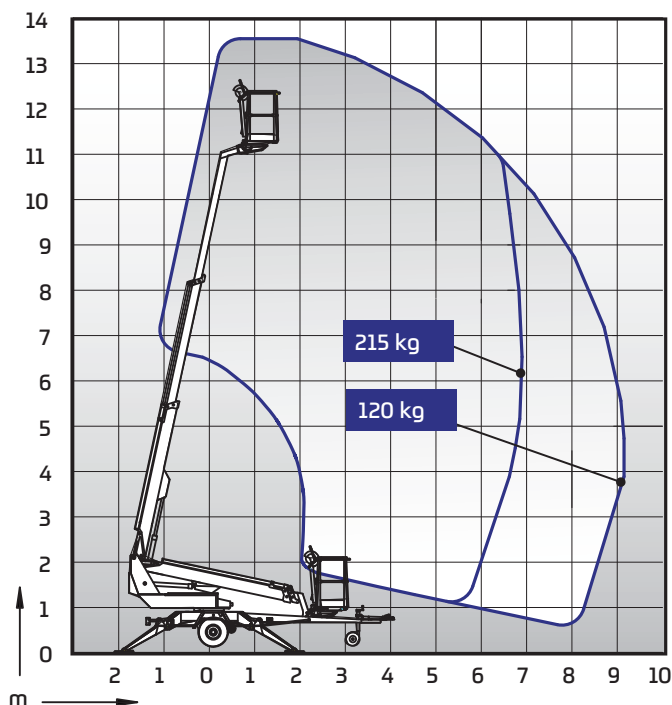

# DINOLIFT

UP TO THE JOB

DINOLIFT Oy | Raikkolantie 145 • FI-32210 LOIMAA, FINLAND

Tel: +358 (0)20 1772 400 • E-mail: info@dinolift.com

Read more: [www.dinolift.com](http://www.dinolift.com)

Technical specifications are subject to change without prior notice.

©Dinolift Oy | 23.5.2017